

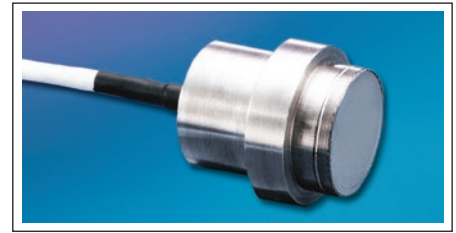

# FLUSH DIAPHRAGM PRESSURE TRANSDUCERS

**IPT-750 SERIES    BM-750 SERIES**

- High Output
- Silicon on Silicon Integrated Sensor **VIS®**
- Hygienic Construction
- Process Instrument Compatible
- Flush Stainless Steel Diaphragm
- Hermetic Sealed Connector (BM-750)
- Intrinsically Safe Applications Available (i.e. IS-IPT-750 or IS-BM-750)



This midsize range of Kulite pressure sensors, incorporating flush stainless steel diaphragms, are designed as general purpose measuring instruments. These units incorporate a four arm active semiconductor chip isolated from pressure media by an oil barrier and stainless steel membrane.

Typical applications include tank contents, head pressure and soil stress measurement. The units are manufactured to allow cleaning by sterilization when used in the food processing industry and medical field. Sealing is accomplished with an o-ring. Typical mounting configuration requires a clamp situated behind the .930 diameter shoulder. By using a standard inlet port adaptor, the unit can be converted for pipe mounting applications.

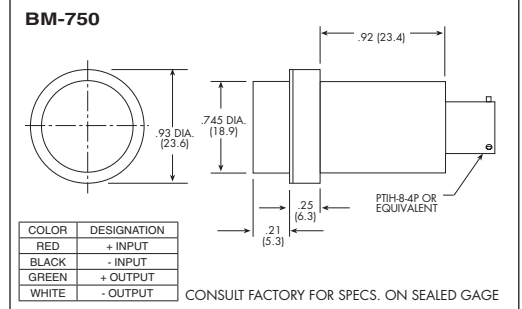
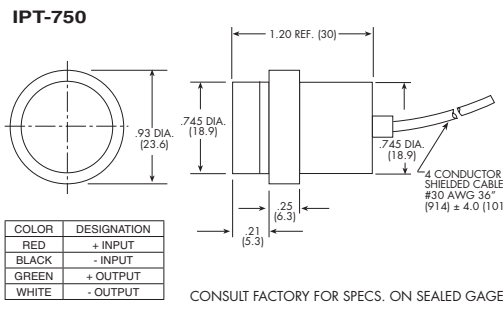
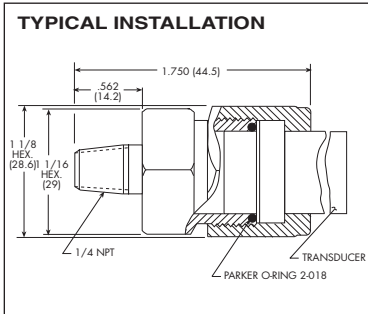

<b>INPUT</b>	Pressure Range	1.7 25	3.5 50	7 100	17 250	35 BAR 500 PSI
	Operational Mode	Absolute, Sealed Gage, Gage (Consult Factory For Vented Gage)				
	Over Pressure	2 Times Rated Pressure Range				
	Burst Pressure	3 Times Rated Pressure Range				
	Pressure Media	Any Liquid or Gas Compatible With 17-4 PH or 316 SS				
	Rated Electrical Excitation	10 VDC/AC (RMS)				
	Maximum Electrical Excitation	12 VDC/AC (RMS)				
	Input Impedance	1000 Ohms (Min.)				
<b>OUTPUT</b>	Output Impedance	1000 Ohms (Nom.)				
	Full Scale Output (FSO)	100 mV (Nom.)				
	Residual Unbalance	± 5 mV (Typ.)				
	Combined Non-Linearity, Hysteresis and Repeatability	± 0.1% FSO BFSL (Typ.), ± 0.5% FSO (Max.)				
	Resolution	Infinitesimal				
	Natural Frequency of Sensor (KHz) (Typ.)	120	210	285	425	550
<b>ENVIRONMENTAL</b>	Insulation Resistance	100 Megohm Min. @ 50 VDC				
	Operating Temperature Range	-65°F to +250°F (-55°C to +120°C)				
	Compensated Temperature Range	80°F to +180°F (25°C to +80°C) Other Ranges Quoted on Request				
	Thermal Zero Shift	± 1% FS/100°F (Typ.)				
	Thermal Sensitivity Shift	± 1% /100°F (Typ.)				
	Linear Vibration	100g Peak, Sine 10 to 5000 Hz				
	Humidity	100% Relative Humidity				
<b>PHYSICAL</b>	Mechanical Shock	100g half Sine Wave 11 msec. Duration				
	Pressure Port	Flush Mount, Unthreaded (1/4" N.P.T. Male SS Adaptor Available)				
	Electrical Connection	4 Conductor 30 AWG Shielded Cable 36" Long (IPT-750)			PTIH-8-4P or Equivalent (BM-750)	
	Weight	39 Grams Approx. (IPT-750)			42 Grams Approx. (BM-750)	
	Sensing Principle	Fully Active Four Arm Wheatstone Bridge Dielectrically Isolated Silicon on Silicon				
Mounting Torque	100 Inch-Pounds (Max.) For Inlet Port Adaptor					

Note: Custom pressure ranges, accuracies and mechanical configurations available. Dimensions are in inches. Dimensions in parenthesis are in millimeters. All dimensions nominal. (H) Continuous development and refinement of our products may result in specification changes without notice. Copyright © 2014 Kulite Semiconductor Products, Inc. All Rights Reserved.